

# **RAD**



## **ROLLER MILL 200 & 300**

[www.radeq.ca](http://www.radeq.ca) • [info@radeq.ca](mailto:info@radeq.ca)

5490, Martineau Street, Saint-Hyacinthe (Québec) Canada J2R 1T8  
Phone: (450) 796-2626 / Toll free: 1-888-796-2723 / Fax: (450) 796-1830

## ROLLER MILL MODEL 200 & 300

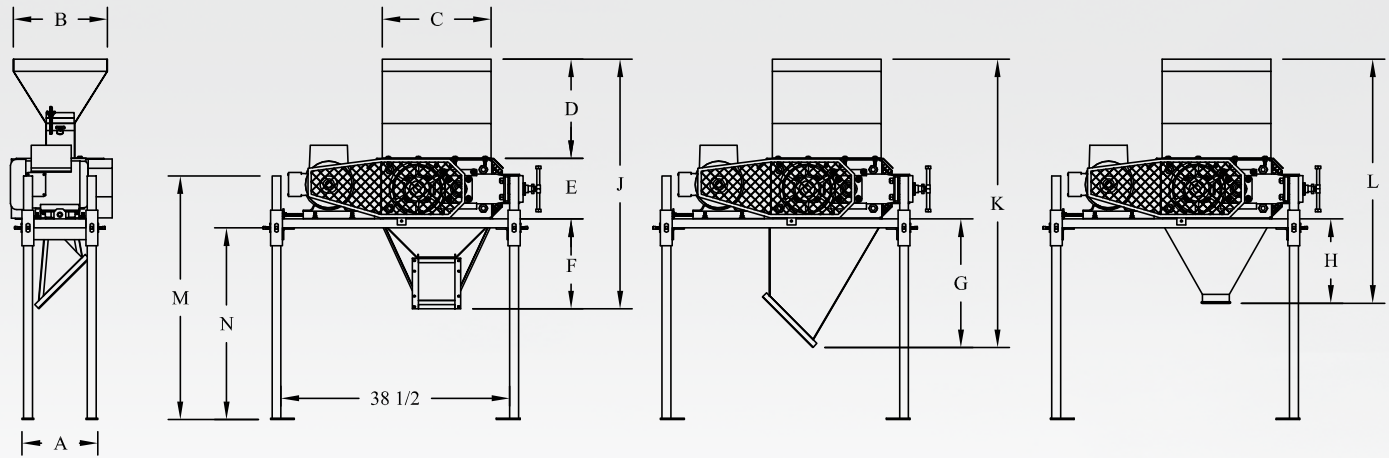

END VIEW

45° PERPENDICULAR OUTLET

45° PARALLEL OUTLET

BAGGING OUTLET

MODEL	DIMENSIONS												
	A	B	C	D	E	F	G	H	J	K	L	M	N MAX.
200	12 3/4	15 7/8	18 1/4	16 3/4	10 1/4	15 1/8	21 5/8	14 1/8	42	48 5/8	41 1/8	41	38 1/2
300	15 3/4	15 7/8	18 1/4	16 3/4	10 1/4	15 1/8	21 5/8	14 1/8	42	48 5/8	41 1/8	41	38 1/2

### SPECIFICATIONS AND CAPACITY OF SINGLE ROLLER MILL

MODEL	ROLLER DIAMETER	ROLLER WIDTH	CORRUGATION (TEETH/INCH)	DRY CORN	HIGH MOISTURE CORN	DRY SMALL GRAIN	HIGH MOISTURE SMALL GRAIN
200	6 1/2"	4 1/2"	5	4.3 T/H	3.7 T/H	—	—
			8.5 (INCLINED)	2.7 T/H	2.5 T/H	1.5 T/H	1.2 T/H
			10.5	—	—	1.2 T/H	1.0 T/H
300	6 1/2"	7 1/2"	5	7.0 T/H	2.5 T/H	—	—
			8.5 (INCLINED)	4.5 T/H	4.2 T/H	2.5 T/H	2.0 T/H
			10.5	—	—	2.1 T/H	1.7 T/H

### SUGGESTED MOTOR

MODEL	GRAIN	HP	RPM
200	CORN	2	1800
	BARLEY	3	1800
300	CORN	3	1800
	BARLEY	5	1800

Specifications are subject to change without notice.

- \* 57 ROCKWELL C TEMPERED STEEL ROLLER
- \* HEAVY STEEL ROBUST CONSTRUCTION
- \* EASY ACCESS MAGNET DRAWER
- \* EASY PRESSURE AND SPACING OF THE ROLLERS
- \* SAFETY MECHANISM IN CASE OF FOREIGN OBJECT PASSING
- \* OTHERS ACCESSORIES AVAILABLE

MANUFACTURED BY: **RAD Équipments inc.**  
 5490, Martineau Street  
 St-Hyacinthe, Quebec, Canada J2R 1T8  
**Phone: (450) 796-2626 1-888-796-2723**  
**Fax: (450) 796-1830**  
**E-mail: info@radeq.ca**  
**Internet: www.radeq.ca**

# RAD

DISTRIBUTED BY :